

10 min	x1	x2

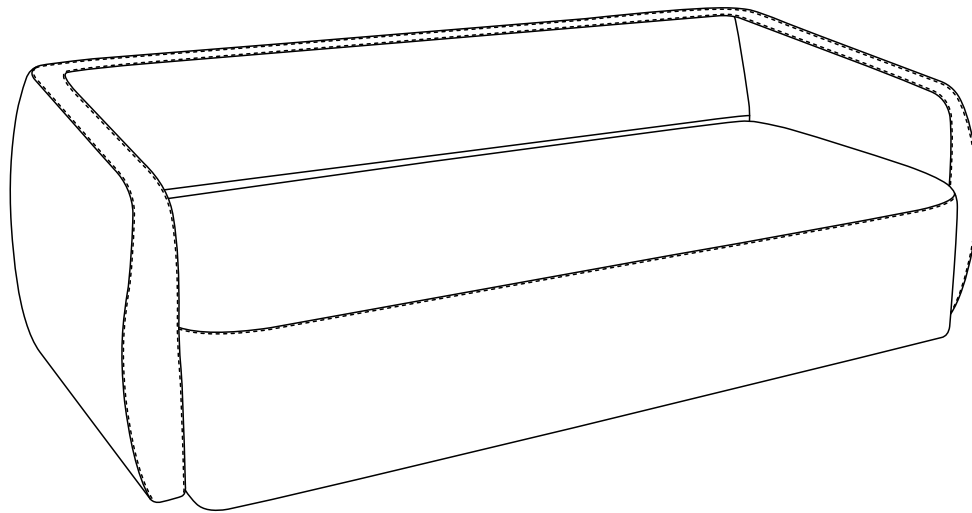

A x1

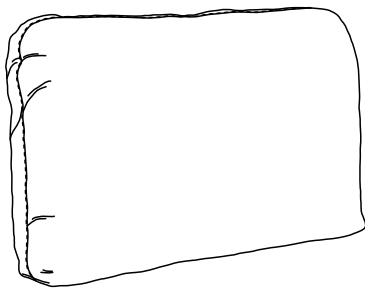
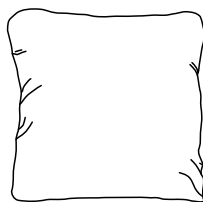

B x3



C x2

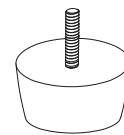

D x6

1

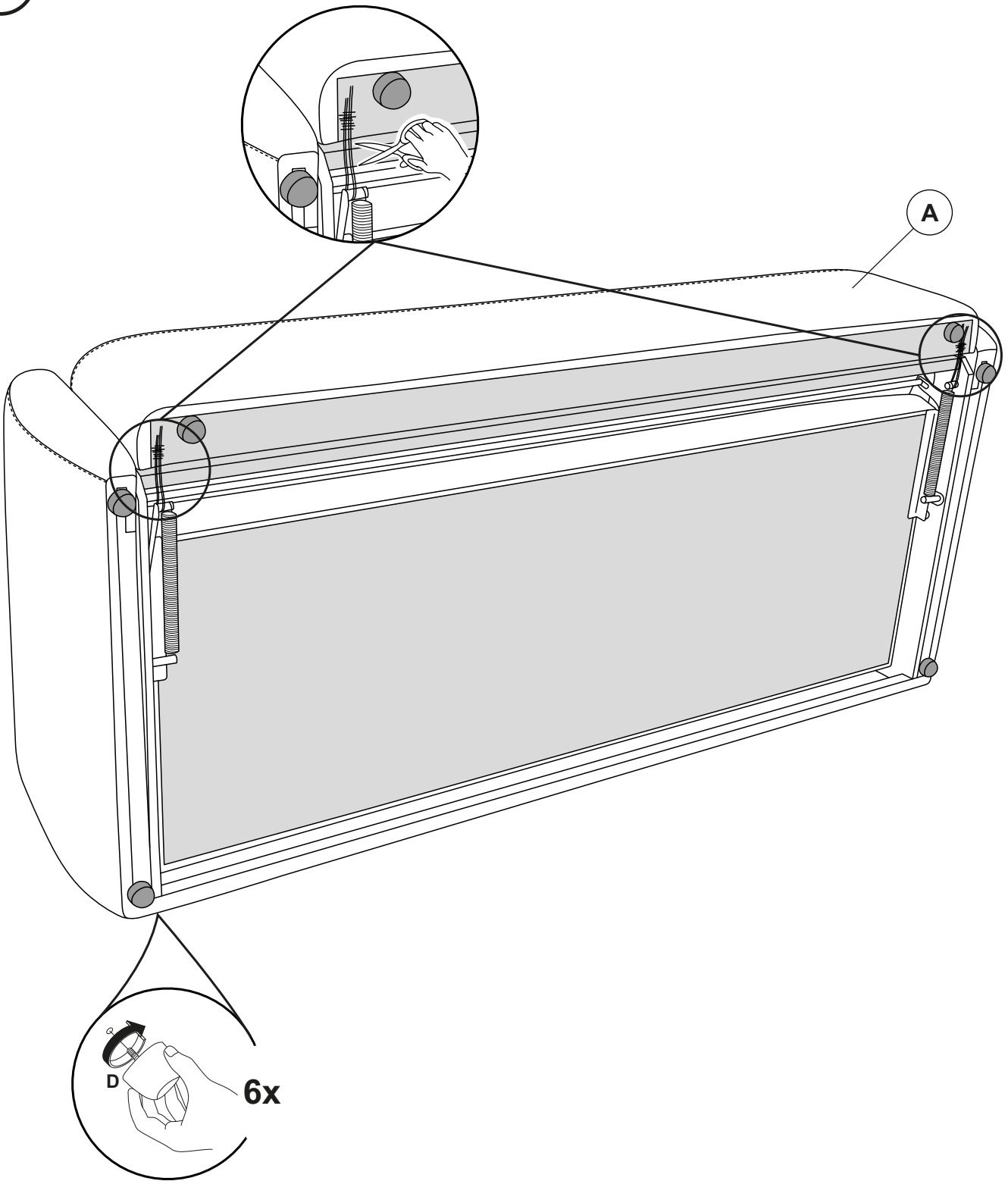

2

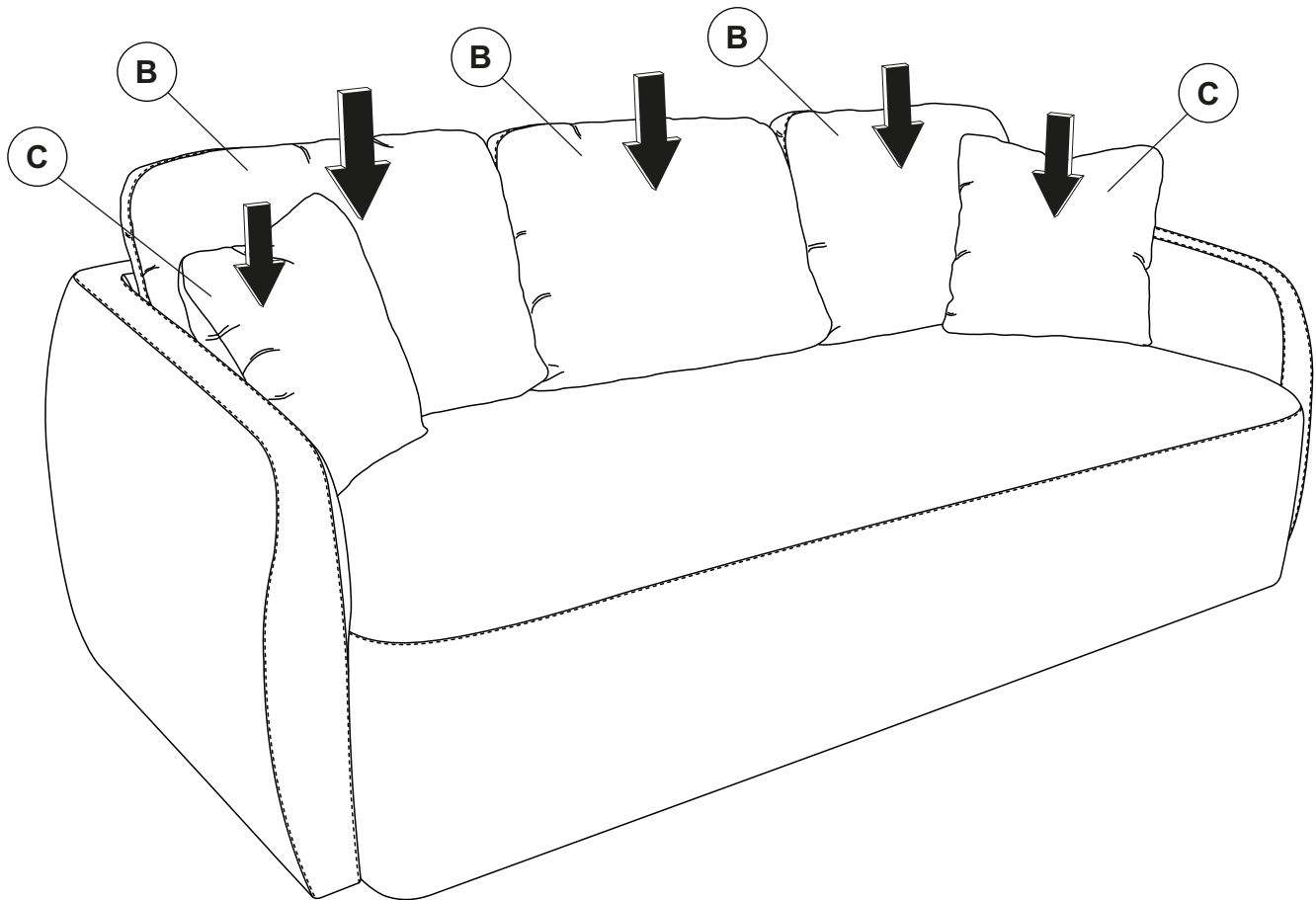

3

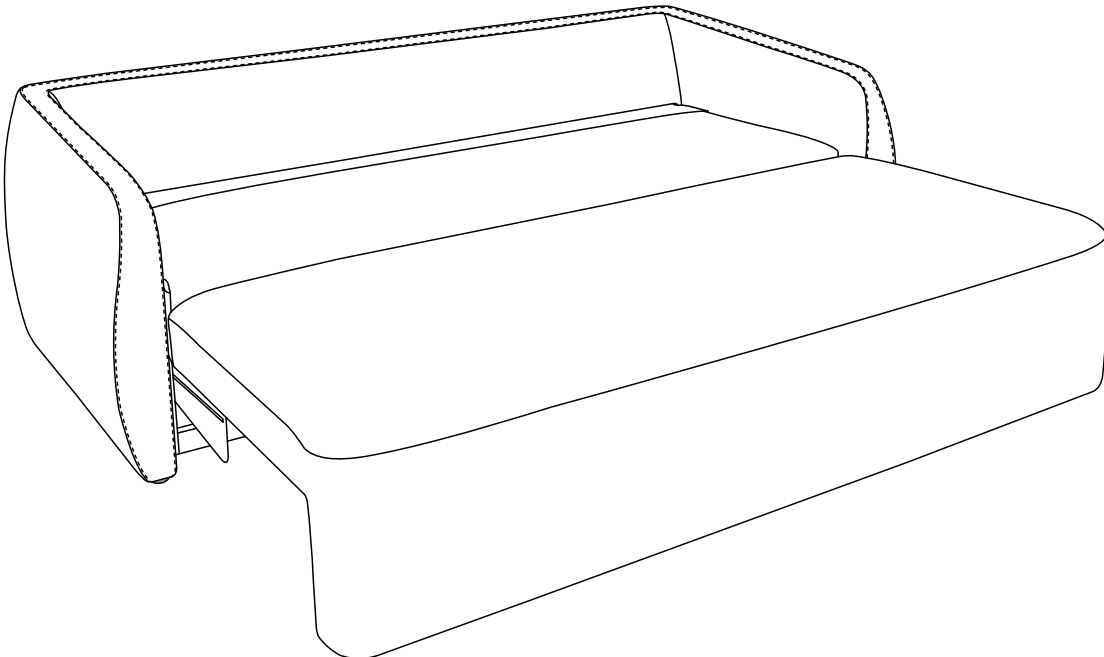
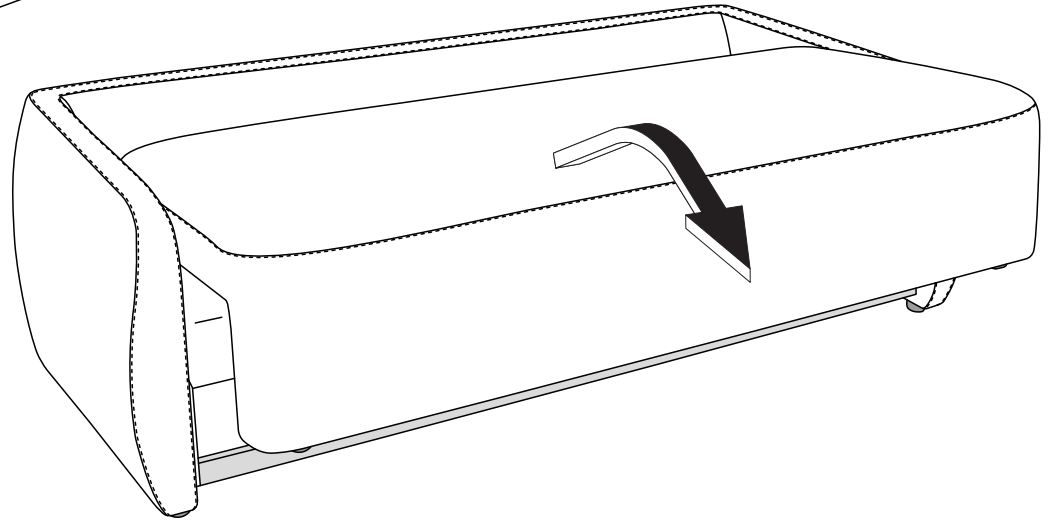
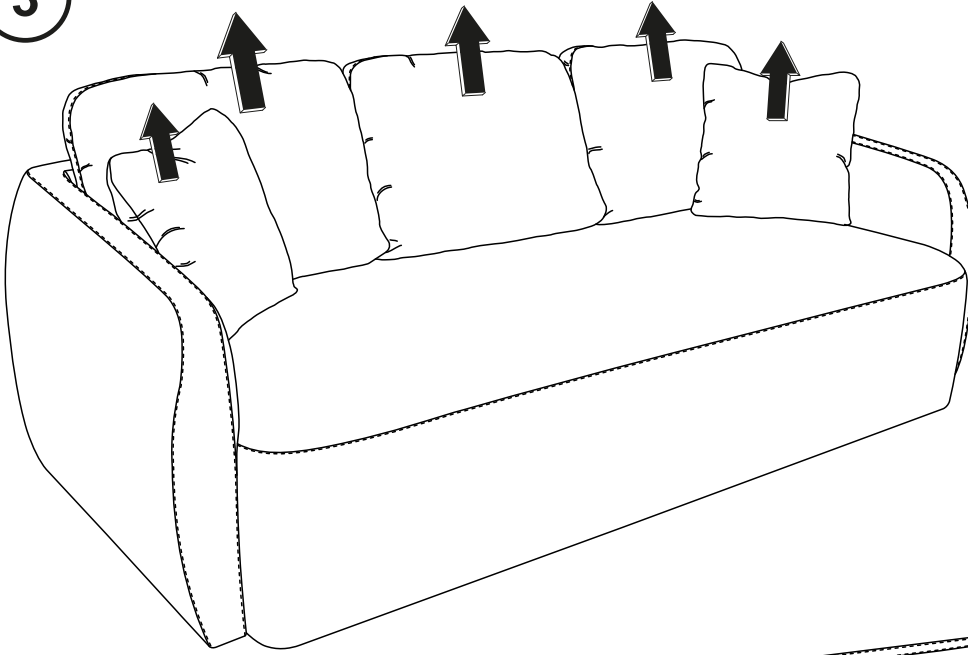

THAT'S ALL FOLKS

Share your style!

#KaveHome

